









# Vanguard™ Drawing Room Table

## Assembly Instructions

For VAN42  
VAN48

**Tools required:** Phillips screwdriver, slotted screwdriver.

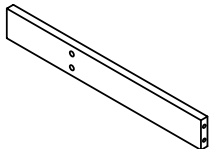
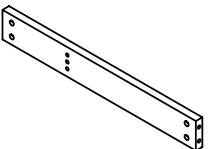
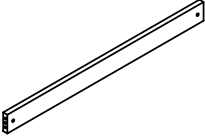
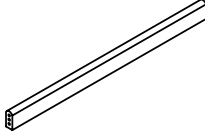
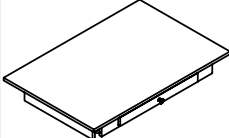
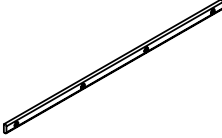
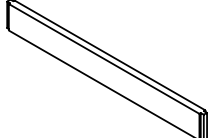
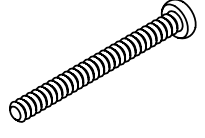
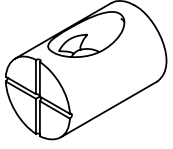
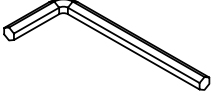
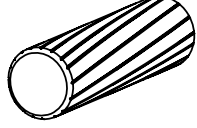
- Important notes:**
1. Power tools for assembly are not recommended. Great care must be taken to avoid over-tightening screws so that holes are not stripped accidentally.
  2. Wood products can be easily scratched if not handled carefully. Please use care when unpacking and assembling to prevent damage.

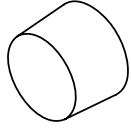
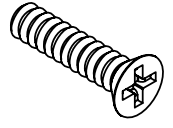
<b>1</b>  Leg - Back Left 1 pc	<b>2</b>  Leg - Front Left 1 pc	<b>3</b>  Leg - Back Right 1 pc	<b>4</b>  Leg - Front Right 1 pc	<b>5</b>  Side Rail - Left 1 pc	<b>6</b>  Side Rail - Right 1 pc
<b>7</b>  Back Rail 1 pc	<b>8</b>  Footrest 1 pc	<b>9</b>  Tabletop Assembly 1 pc	<b>10</b>  Pencil Ledge 1 pc	<b>11</b>  Drawer Dividers 2 pcs	<b>A</b>  Bolts, 2 1/4" 22 pcs
<b>B</b>  Barrel Nuts 14 pcs	<b>C</b>  Allen Wrench 1 pc	<b>D</b>  Wood Dowels 14 pcs	<b>E</b>  Washers 8 pcs	<b>F</b>  Wood Plugs 10 pcs	<b>G</b>  Bolts, 1/2" 4 pcs

### How To Install Bolts and Barrel Nuts

- 1** Insert barrel nut (**B**) in predrilled hole of side rails (**5 & 6**).
- 2** Use screwdriver to ensure long slot is aligned with bolt (**A & G**).
- 3** Insert bolt and tighten.
- 4** Long slot in barrel nut must align with bolt.

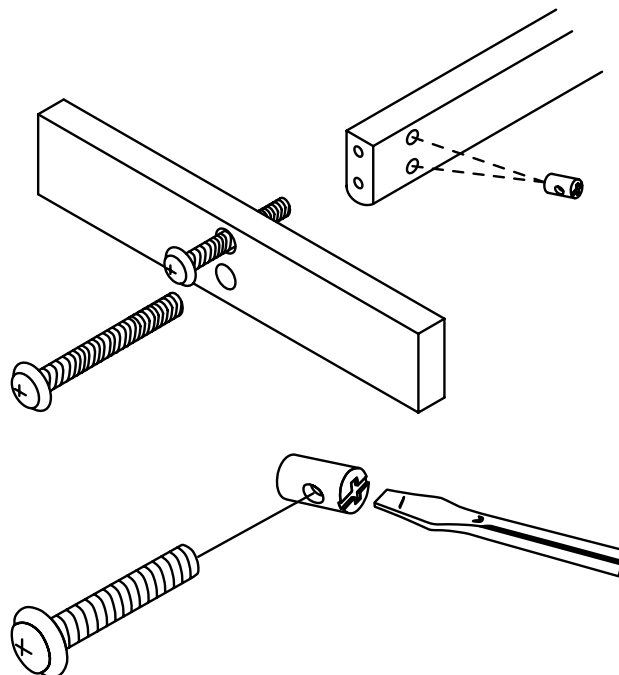

## Step 1

- 1** Remove parts from carton and check that all are present. For ease of handling and assembly, do not cut plastic wrap around tabletop assembly (**9**) until the end of the assembly process.
- 2** Use care in handling all parts to prevent scratches and other damage. Two people will be necessary to lift tabletop assembly from carton.
- 3** Place tabletop assembly on a carpeted or otherwise protected floor with the drawer unit facing up, as shown in *Figure 1*.
- 4** Each leg is numbered (**1-4**) and must be attached to the corner with corresponding number.
- 5** Insert two dowels (**D**) in each leg (no glue necessary) and attach legs to tabletop assembly using 2¼" bolts (**A**) and washers (**E**). Keep all leg bolts slightly loose to allow for assembly steps to follow.

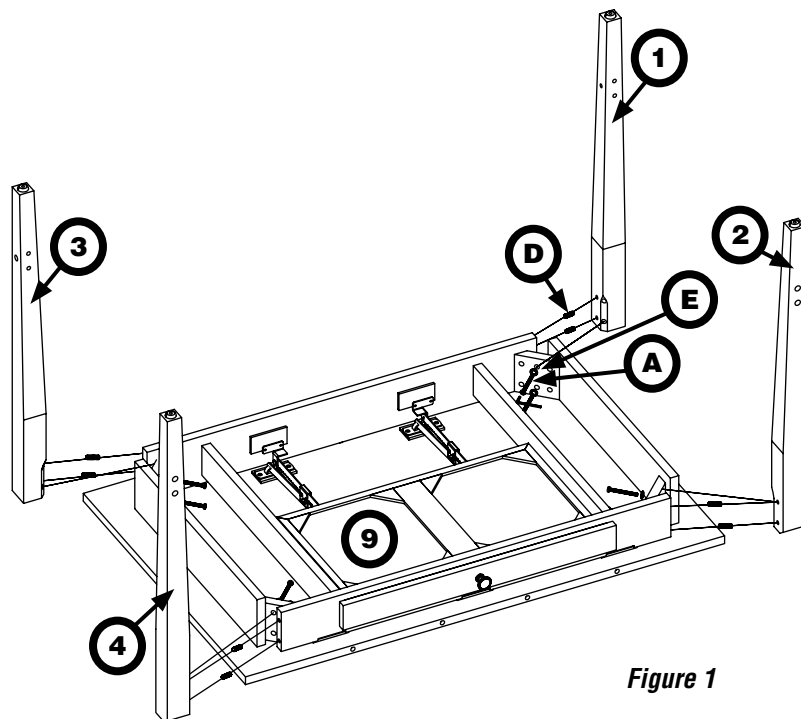

Figure 1

## Step 2

- 1** Side rails (**5 & 6**) have angled ends and off-center middle holes. They are not interchangeable.
- 2** The face of each side rail with seven holes should face in.
- 3** The middle three holes should be closest to the back of the table (furthest from drawer knob).
- 4** Double-check that angled ends align properly with legs before bolting.
- 5** Connect side rails between legs using 2¼" bolts and barrel nuts (**B**) as shown in *Figure 2*. Keep all bolts slightly loose to allow for assembly steps to follow.

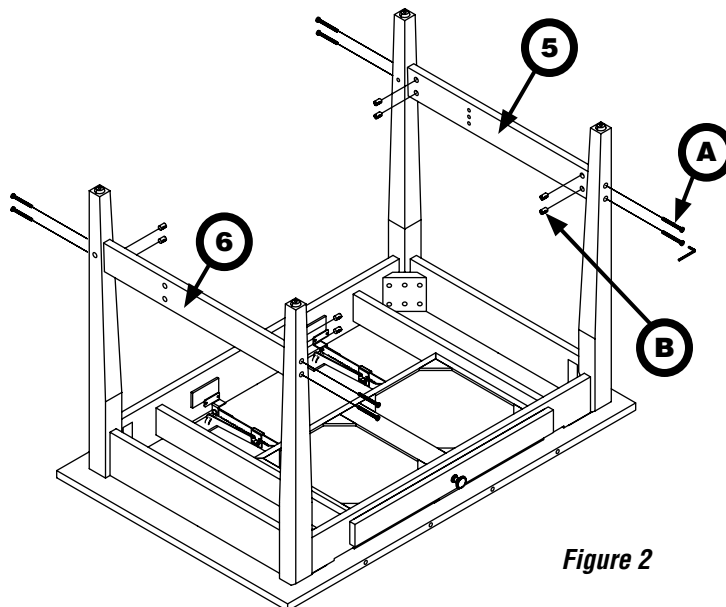

Figure 2

## Step 3

- 1** Back rail (**7**) has angled ends. Double-check alignment with legs before bolting in place.
- 2** Insert 2 dowels into each end of back rail (no glue necessary).
- 3** Connect back rail between legs using 2¼" bolts and barrel nuts as shown in *Figure 3*. Keep bolts slightly loose.
- 4** Insert 1 dowel into each end of footrest (**8**) (no glue necessary).
- 5** Connect footrest between legs using 2¼" bolts and barrel nuts. Rounded edge should face tabletop. Keep bolts slightly loose.

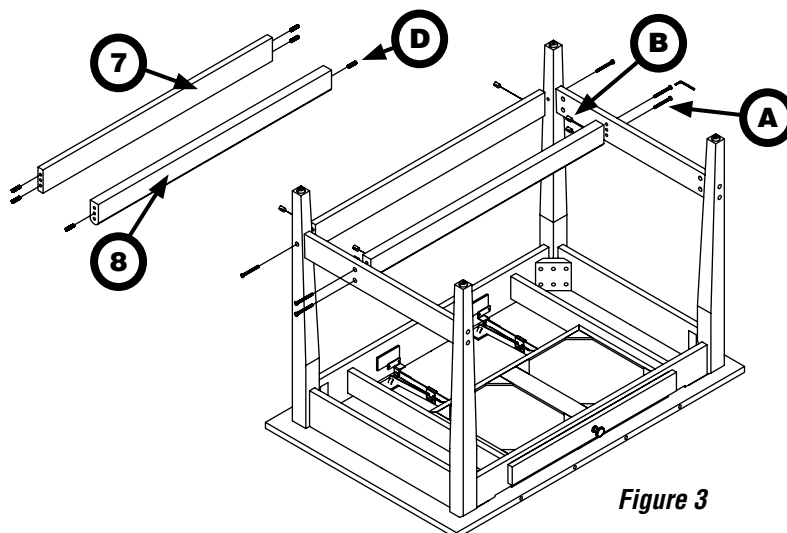

Figure 3

## Step 4

### Bolt Tightening Sequence

Tighten all (22) 2¼" bolts using the following sequence. We recommend a gradual tightening process in which you go through the sequence a few times and tighten the bolts more each time. This will ensure good joint alignment. Pay special attention that the legs align well with the tabletop assembly.

- 1** Footrest to side rails first.
- 2** Side rails to legs second.
- 3** Back rail to legs third.
- 4** Legs to tabletop assembly fourth.

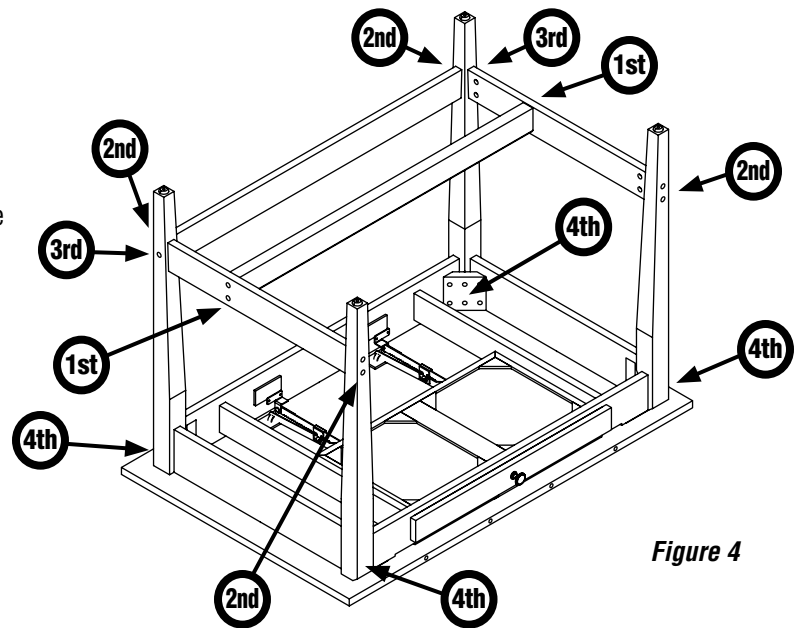

Figure 4

## Step 5

- 1** Without cutting plastic wrap yet, lift from under the tabletop (not the legs) and carefully flip table into the upright position. This will require two people. Use care to prevent scratches or other damage.
- 2** Cut plastic wrap.
- 3** Pencil ledge (**10**) has two functions, depending on which edge faces up. The raised position prevents materials from sliding off the tilted surface. The flush position provides a comfortable, rounded edge for your forearms.
- 4** Choose which position you desire and attach pencil ledge to front edge of tabletop using 1/2" bolts (**G**) into threaded inserts, as shown in Figure 5. Tighten firmly using care not to strip.

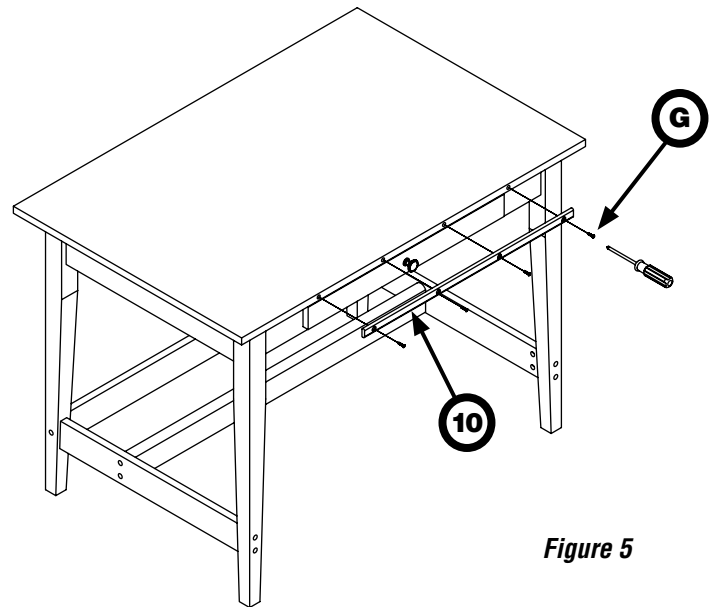

Figure 5

## Step 6

- 1** Lift back of tabletop into an elevated tilt position to gain access to back of drawer. (See directions for adjusting tilt on the last page of these instructions.)
- 2** Insert drawer dividers (**11**) into desired slots as shown in Figure 6.

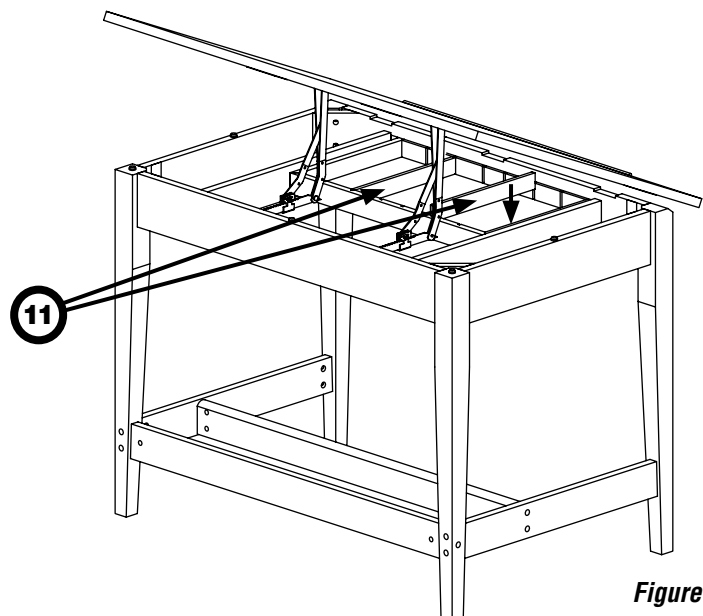

Figure 6

## Step 7

- 1** Now that your table assembly is nearly complete, we recommend that you go back and tighten all the leg bolts and screws one more time. This will ensure that your table remains strong, sturdy, and stable for years of use.
- 2 Optional** Insert the wood plugs (**F**) into each of the bolt holes as shown in *Figure 7*. Gently tap into place. Please don't install with permanent adhesive. Since wood products have a tendency to expand and contract from season to season, we recommend that you remove the wood plugs and retighten the bolts every 6 months.

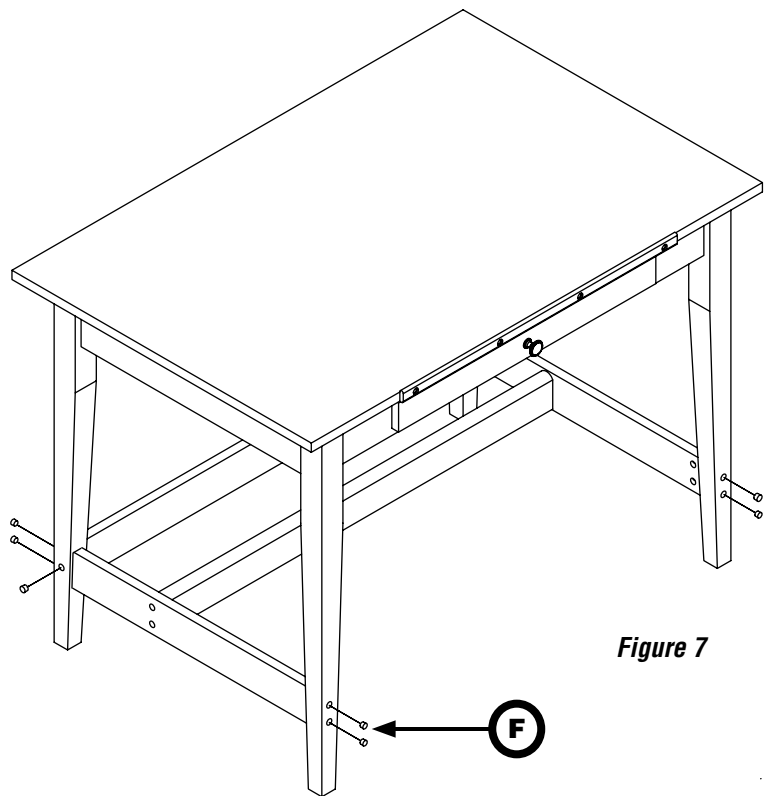

Figure 7

## USAGE INSTRUCTIONS

### Adjust Tilt

The ratcheted tilt mechanisms allow you to set the tabletop to a variety of comfortable working angles. Simply lift the tabletop from the back edge until it clicks into the desired position. To return the top to the flat position, raise the back edge as high as it will go. This will release the ratchet mechanism allowing the top to be lowered.

### Pencil Ledge

Pencil ledge has two functions, depending on which edge faces up. The raised position prevents materials from sliding off the tilted surface. The flush position provides a comfortable, rounded edge to rest your forearms against.

### Repositionable Drawer Dividers

The drawer has numerous slots for the dividers, depending on the things you plan to store. It is easiest to reposition the dividers from the back of the table. Close the drawer fully and lift the tabletop to its highest tilt position for easiest access.

### Care Instructions

Clean like any other piece of fine wood furniture. Use a soft cloth and avoid harsh or abrasive cleansers.

### Seasonal Adjustments

Since wood products have a tendency to expand and contract from season to season, remove wood plugs and retighten all the bolts every 6 months. This will ensure that your table remains strong, sturdy, and stable for years of use.



Please recycle as much of the packaging materials as possible. Thank you.

Thank you for purchasing this Alvin® table

Need assistance with assembly? Call customer service at 1-800-444-2584. Visit us online at [www.alvinco.com](http://www.alvinco.com).